

# CE-400

## Automatic Wastewater Treatment

### Standard Features

- Fully Automatic Operation with Manual Overrides
- Maximum Throughput: 1200 gph
- 400-Gallon Treatment Tank
- Allen Bradley Micrologix PLC Controls
- U.L. Approved Control Panel
- 3 Horsepower Heavy Duty Agitator with Jet Basket
- Treatment Tank Auto Washdown
- Pre-Plumbed for Effluent Pump
- Automatic Chemical Feed System with 300 lb. Hopper, Complete with 2000 lb. Superbag Support Frame
- Double Rollers for Greater Dewatering
- **Equipment Measurements:** Length: 10'4", Width: 7'4", Height: 11'11", Weight: 5,000 lbs.

### Optional Features

- 3.0 Cubic Yard Dumpster with False Bottom for Dewatering
- pH Control System for Treatment Tank
- Stainless Steel Construction
- 2" Cast Iron Influent Diaphragm Pump
- 2" Aluminum Effluent Diaphragm Pump
- Auto Washdown for Filtrate Tank
- Equalization and Reuse Tanks



(System shown with stainless steel option)

*Ringwood's wastewater treatment units optimize the use of clay based flocculants to clarify industrial wastewaters.*

**Ringwood Environmental, Inc. Wastewater Products**

6715 West 73rd Street • Bedford Park, IL 60638 • 708.458.6000 • FAX 708.458.1051

# CE-400

## Automatic Wastewater Treatment

NOTE: Items in **RED** are standard equipment that can be located on either side of the CE-400. Items in **BLUE** are optional equipment.

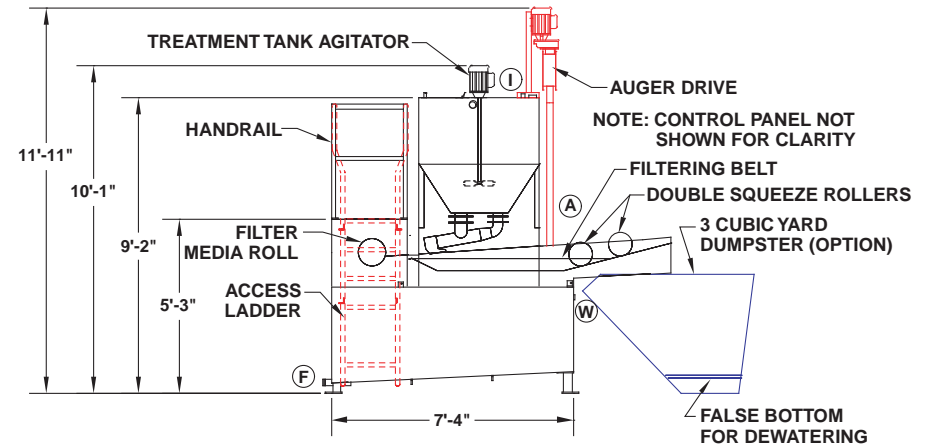
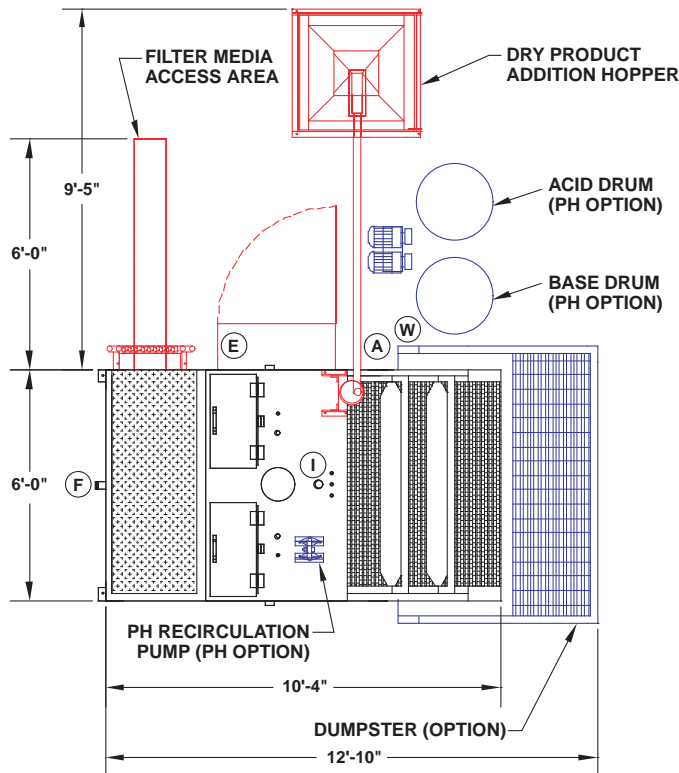

### Service Requirements

- E** 480 VAC, 30 AMP, Grounded, 3 Phase Power Terminated at the Disconnect in the CE-400 Control Panel.
- A** 1" FNPT Air Supply Connection. 80-100 PSI, Clean, Dry, Air Required, With Locking Handle Valve on Service Line.
- W** 1" FNPT City Water Supply Connection. 30 PSI Required, With Locking Handle Valve on Service Line.
- I** 2" FNPT Influent Water Inlet Connection.
- F** 2" MNPT Effluent Water Discharge Connection.

**Ringwood Environmental, Inc. Wastewater Products**

6715 West 73rd Street • Bedford Park, IL 60638 • 708.458.6000 • FAX 708.458.1051